

16V
4013

Mercedes Sprinter, Modell 2013

EU-Personenschutzbügel 60 mm mit integriertem Querrohr 42 mm

EU-pedestrian protection bar 60 mm with cross pipe 42 mm

Barre de protection des piétons UE de 60 mm avec tube transversal intégré 42 mm



*Compatible with Automatic Cruise Control /Forward Collision Mitigation
Kompatibel mit Abstandsregeltempomat /Auffahrvermeidungs-oder warnsystem
compatible avec radar de régulation de distance/ freinage autonome d'urgence

ASSEMBLY INSTRUCTION

Montageanleitung • Instructions de montage



45 Minuten

article no.:

16V4013 (S) inox

16V5013 black steel

Revision 5: 19.11.2018



www.antec-online.de

M8:
25 Nm
M8 (A2):
21,4 Nm
M12:
87 Nm



Ø 12,5
Ø 30

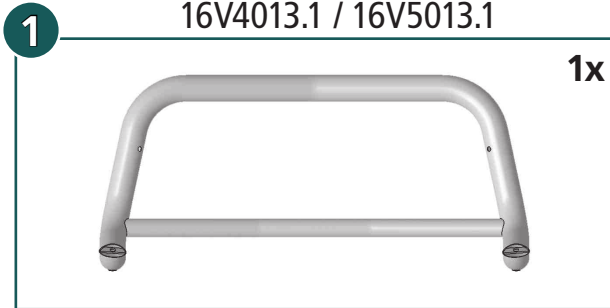
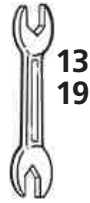

mounting kit: 16V9013

	M8x40; DIN 933 Zn	2x
	M8x20; DIN 933 A2	2x
	M12x25x1,5; DIN 961 Zn	2x
	M8x30; DIN 912 A2	2x
	Ø 8,4; DIN 125 A2	2x
	SW 13 mm	4x

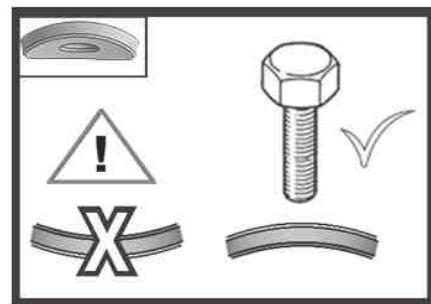
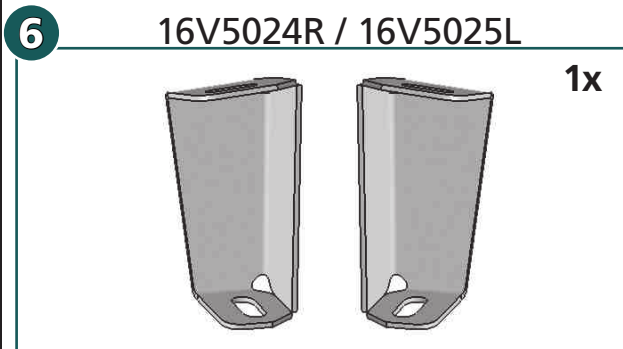
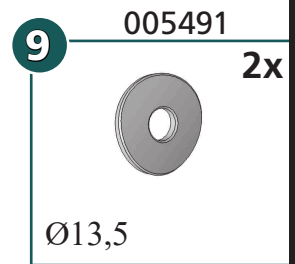
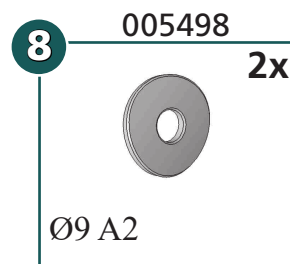
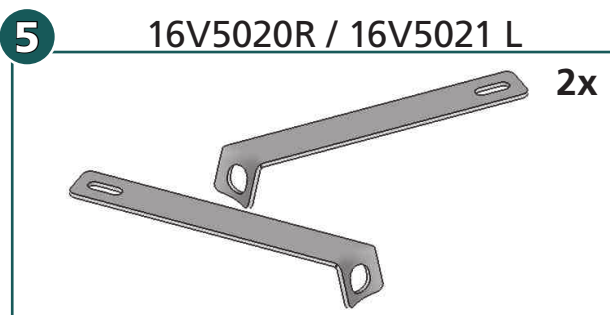
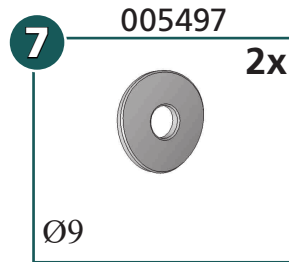
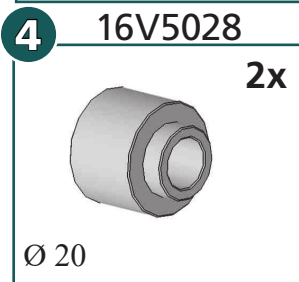
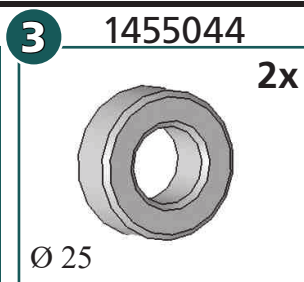
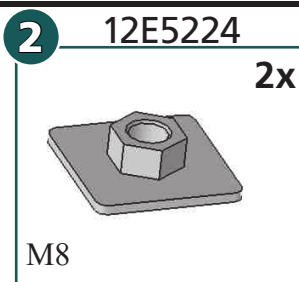

article no.:

16V4013 (S) inox

16V5013 black steel

Revision 5: 19.11.2018



